

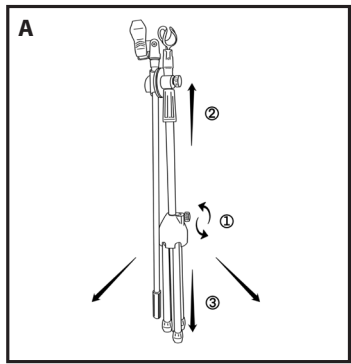

MANUALE DI ISTRUZIONI
INSTRUCTION MANUAL

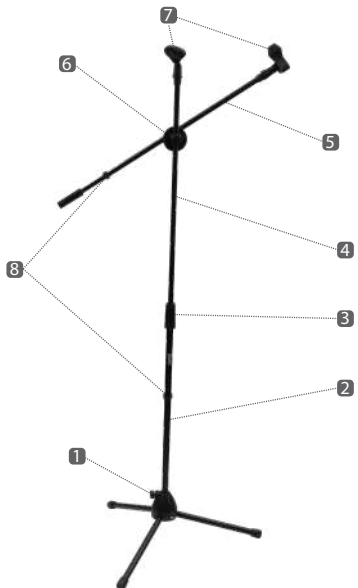

ISTRUZIONI DI MONTAGGIO ASTA PER MICROFONO CTC19000



- ① Allentare la vite (1) girando in senso antiorario
- ② Tirare verso l'alto l'asta centrale (2)
- ③ Allargare il treppiede.

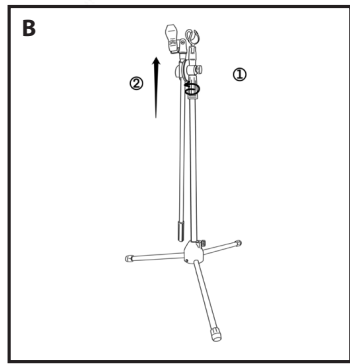

- ① Ruotare la manopola (3) in senso antiorario
- ② Tirare verso l'alto l'asta estensibile (4).

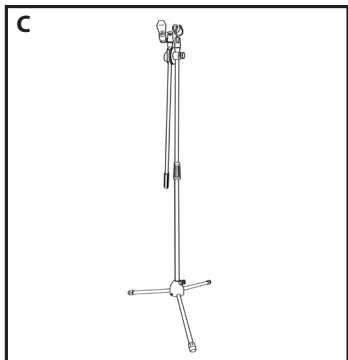

Ruotare la manopola in senso orario per fissare l'asta.

Allentare la vite (6) per aggiustare l'angolo di inclinazione e la posizione dell'asta (5) che sostiene il microfono. Dopo questa operazione stringere nuovamente la vite (6).

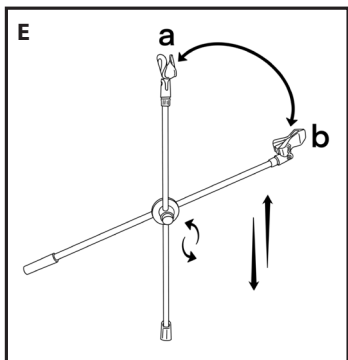
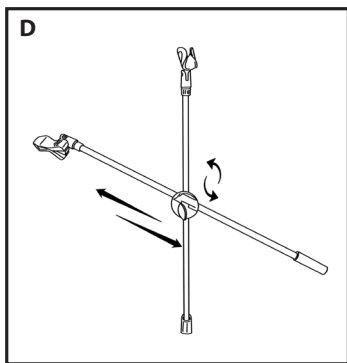

Allentare l'altra vite (6) per regolare l'altezza dell'asta che sostiene il microfono. Posizionare a scelta uno dei due agganci per microfono inclusi (a, b).

ASSEMBLY INSTRUCTIONS MICROPHONE STAND CTC19000

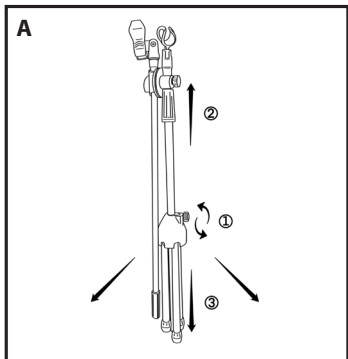
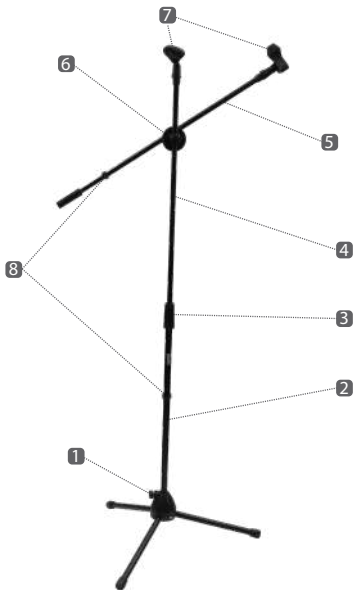

- ① Loosen the screw(1) counterclockwise
- ② Pull up the center rod(2)
- ③ Unfold the tripod

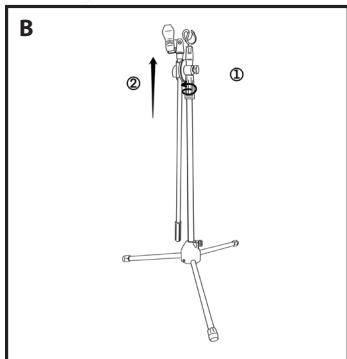

- ① Rotate the Grip(3) Counter Clockwise
- ② Pull out the extension rod(4)

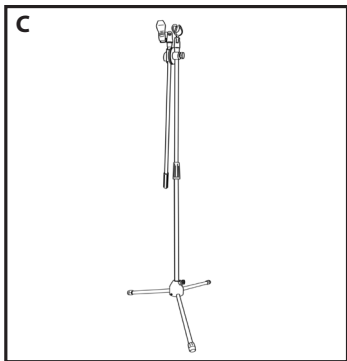

Rotate the handle clockwise to fix the rod.

Loosen the screw(6),to adjust the angle and position below the microphone retaining rod(5).Finally tighten the screw(6)again.

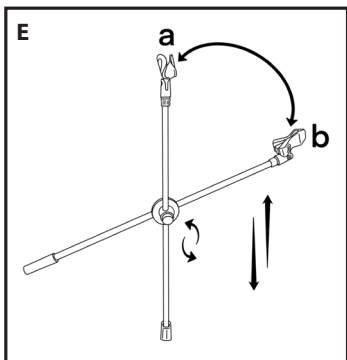
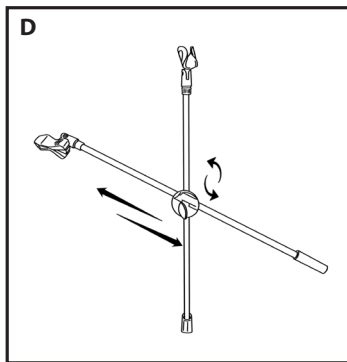

Loosen the other screw(6),to adjust the height of retaining rod(5).
Two microphone holders(a,b) are included and their positions can be exchanged with each other.

INSTRUCCIONES DE MONTAJE SOPORTE PARA EL MICRÓFONO CTC19000

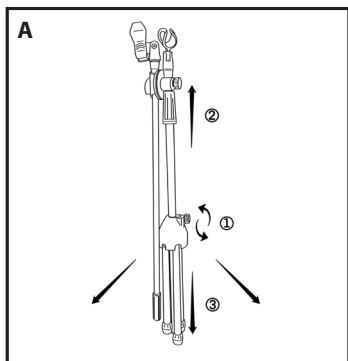
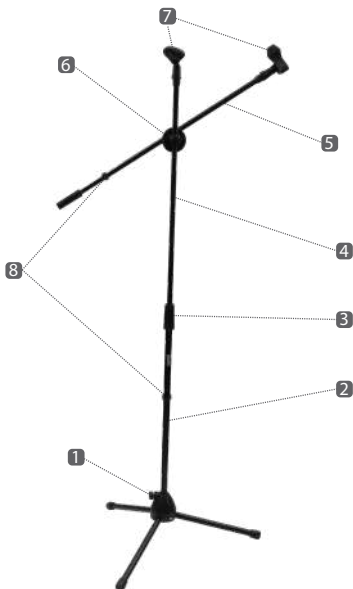

- 1 Aflojar el tornillo (1) en el sentido contrario a las agujas del reloj.
- 2 Tirar la barra central hacia arriba (2).
- 3 Desplegar el trípode.

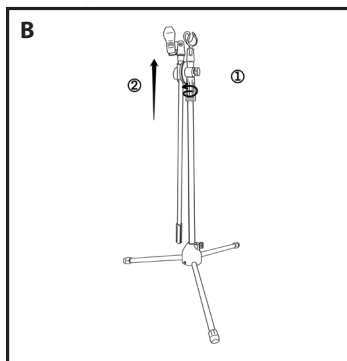

- 1 Girar el mango (3) en el sentido contrario a las agujas del reloj.
- 2 Tirar de la vara extensible (4).

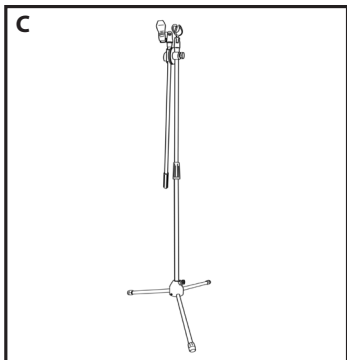

Girar el mango en el sentido de las agujas del reloj para fijar la vara.

Aflojar el tornillo (6) para ajustar el ángulo de inclinación y la posición de la vara (5) que sustenta el micrófono. Volver a apretar el tornillo (6).

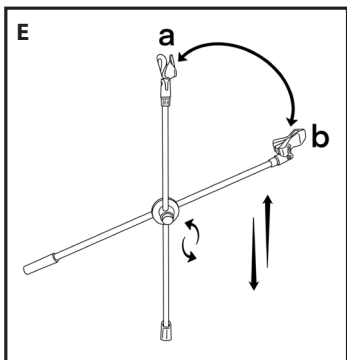
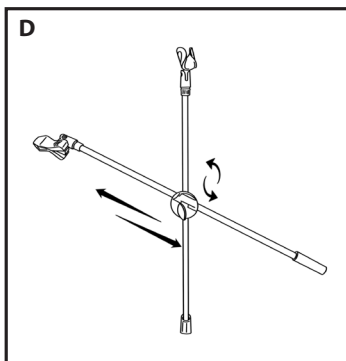

Aflojar el otro tornillo (6), para ajustar la altura de la vara que sustenta el micrófono (5). Colocar uno de los dos ganchos para micrófono incluidos (a, b) en la punta de una de las varas (los ganchos son intercambiables).



©Giochi Preziosi S.p.A. 1992
Canta Tu * | Canta Tu Karaoke® owned by Giochi Preziosi S.p.A.



Flair

